



Creative Automation, Inc.

5404 Jedmed Court - St. Louis, MO 63129
Tel (314) 845-3820
FAX (314) 845-7779



Creative Automation an Engineering and System Integration Company

Creative Automation offers the manufacturing community complete process and packaging system solutions. Our staff includes electrical, mechanical, and computer science engineers with years of experience developing systems for industry. Located in St. Louis, Missouri, Creative Automation and our sister company, Accurate Superior Scale, can help you through the entire design process, including specification of material handling equipment, custom machine design, control system integration and software. Many systems are completely staged at our facility before installation.

Call and let us provide you a Creative solution.

Custom Machine Design/Process Engineering

At Creative Automation, we do custom systems. Below are some projects that involved design of special machines.

Continuous Formulation System

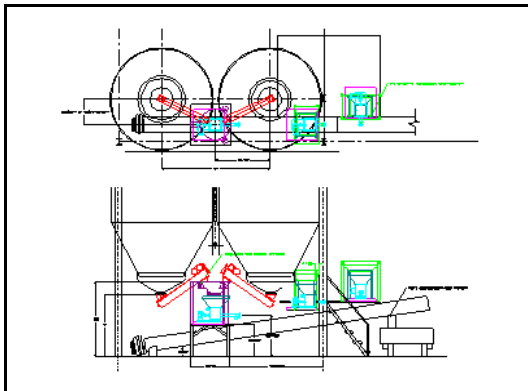

In-motion Checkweighers



Bulk Bag Unloader/Tote Filler

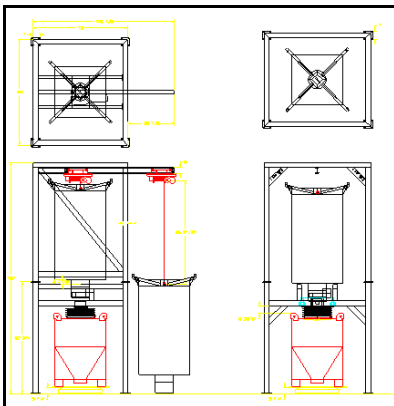

Liquid Drumfiller

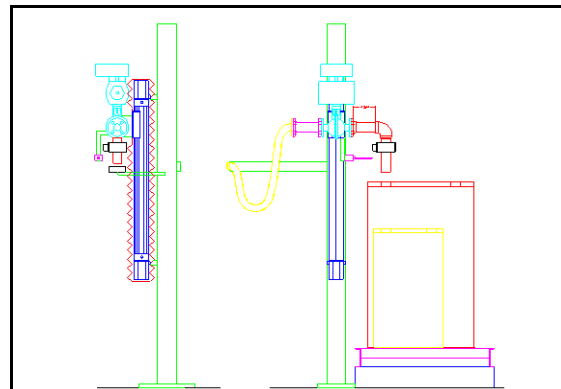

Providing Application Specific Equipment

We implement a variety of process and packaging equipment for a wide variety of applications. This is a short sampling...

- Mass flow devices
- Checkweighers, in-motion and static
- Powder and Liquid Fillers
- Tote and Bulk Bag Fillers/ Unloaders
- Bagging systems
- Conveyor and Palletizing systems
- Volumetric, Loss in Weight, and Screw feeders
- Load cells for process vessels, weight indicators, and other weighing devices
- Truck, and rail Car scales
- Bulk Material Shipping/Receiving
- Loss-in-weight continuous feed systems
- Net weight piece filling systems
- Belt Scales and Weigh Belt Feeders
- Level detection and live Bin Bottoms

Control Systems

At Creative Automation, electrical controls are no problem. These systems show custom control panels for various applications. PLC's, pc MMI interface, pushbutton stations-- whatever your application requires.

Net Weight Packaging System



Batching

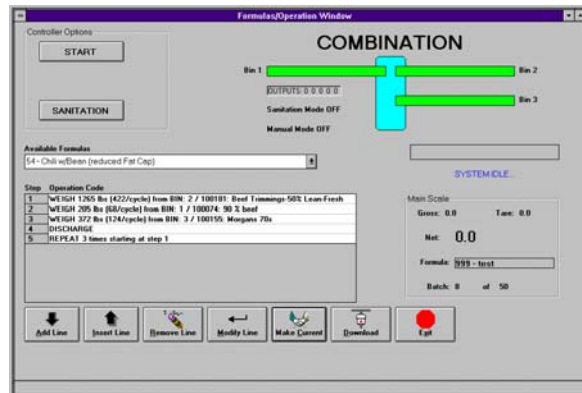

Bulkweigher - Bulk Shipping/Receiving

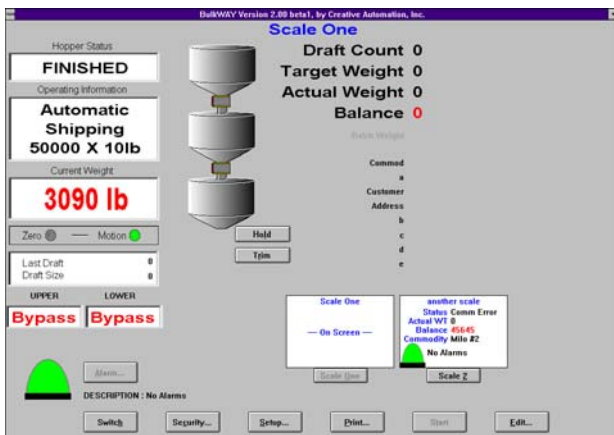

Setpoint Controller

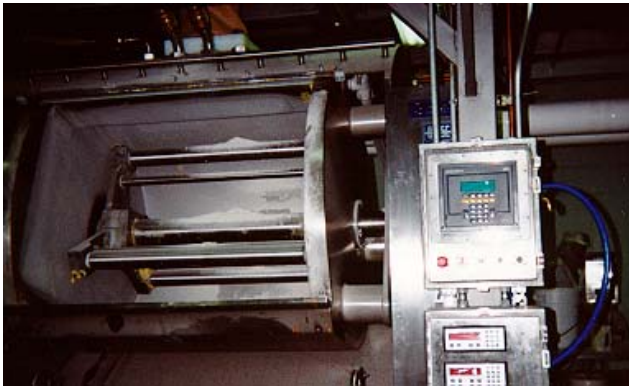

Providing Control Hardware, and Application Software

Your plant maintenance personnel have enough headaches without confusing, proprietary hardware systems and long spare part lead times. Since you cannot afford to be down, we use control hardware that makes *you* comfortable.

Allen-Bradley
PLC-5, SLC, micrologix
Rockwell
IBM
Reliance Automate
GE Fanuc
Modicon
Wintelligent View

Microsoft
DOS, Windows, and Windows NT
Visual Basic
C and Visual C++
inTouch Wonderware
Weigh-Tronix
WI-130
Simposer WT-BASIC

Customers/Applications:

A .P. Green Refractory
ADM Growmark
Anheuser Busch, Inc.
Clark Asphalt
Con-Agra
Conoco Lubricants
Continental Grain
Dial Corp
Genex
Hazelwood Farms Bakeries
Iowa Gateway Terminal
KAO Information Systems

Midwest Biscuit Vista Bakeries Division
Moormans Research Farm
P.M. Resource
PET Foods
Purina Research Farm
Shell Oil
Sigma Chemical
Symons Corp.
Tetra Plastics
United Technologies Automotive
U.S. Gypsum, Inc.

